

DONATA

VITRA DESK

DESIGN BY: GEORGSSEN



A BOLD STATEMENT, A PIECE WITH A REFINED CHARACTER

Featuring a mid-century modern silhouette. Our Vitra desk attracts with its charm and functionality. Its 5 drawers provide enough space to store a variety of office items, books and more. The wood's smoked grey finish contrasts with the steel legs and pulls in an antiqued Brass finish to create a style statement.

Suitable for residential or commercial settings.

Con una silueta moderna de mediados de siglo. Nuestro escritorio Vitra atrae con su encanto y funcionalidad.

Sus 5 cajones brindan suficiente espacio para almacenar una variedad de artículos de oficina, libros y más. El acabado gris ahumado de la madera contrasta con las patas de acero y los tiradores en un acabado de latón envejecido para crear una declaración de estilo.

Adecuado para entornos residenciales o comerciales.

DONATA

REFINED HANDCRAFT TECHNIQUE

The quintessential design of this desks merges the highest quality materials and finishes in order to create a piece that lasts and stays current.

A well-designed desk to add rustic appeal to office spaces.

El diseño exclusivo de este escritorio fusiona materiales y acabados de la más alta calidad para crear una pieza que perdura y se mantiene actual.

Un escritorio bien diseñado para agregar un atractivo rústico a los espacios de oficina.



FINISHING DETAIL

Antiqued Brass

Smoked grey

ELEMENTS USED

Steel

Wood

STRUCTURE

Wood

Steel

COLLECTION

ART MODERN

DETALLADO FINAL

Latón envejecido

Gris ahumado

ELEMENTOS UTILISADOS

Acero

Madera

ESTRUCTURA

Madera

Acero

COLECCION

ART MODERN

DONATA

VITRA DESK

DESIGN BY: GEORGSEN



REF: 109072

MOQ: 20

Desk
Escritorio

DIMENSIONS

Overall Dimensions	W153 x D61 x H76 cm / L60 x W24 x H30"
Gross Weight	
Net Weight	
Pack	1pc / 1ct
Carton Size	W164 x D71 x H45 cm / W64.5 x D28 x H17.5"
CBM	0.518
20FT Container	
40GP Container	
40HQ Container	105

CONSTRUCTION

Material / Cover	Wood
Frame Construction	
Base / Legs	Steel
Base Finish	Antiqued Brass
Structure Warranty	2 years

DETAILS

SKU Number	109072
Collection	ART MODERN
Origin	Vietnam
Assembly required	No

DONATA

VITRA DESK

DESIGN BY: GEORGSSEN



STRUCTURE

High Quality engineered wood
Steel

PARTS AND MECHANISMS

High quality full extension, soft-close glides
Steel / Antiqued Brass handles

BASE

Base in Steel / Antiqued Brass

ESTRUCTURA

Madera MDF de alta calidad
Acero

PARTES Y MECANISMOS

Deslizadores largos de cerrado suave de alta calidad
Tiradores de acero / latón envejecido

BASES

Base en Acero / Latón envejecido

ANTIQUED BRASS



BASE
Steel

BASE
Acero



DONATA

PIECE ELEMENTS

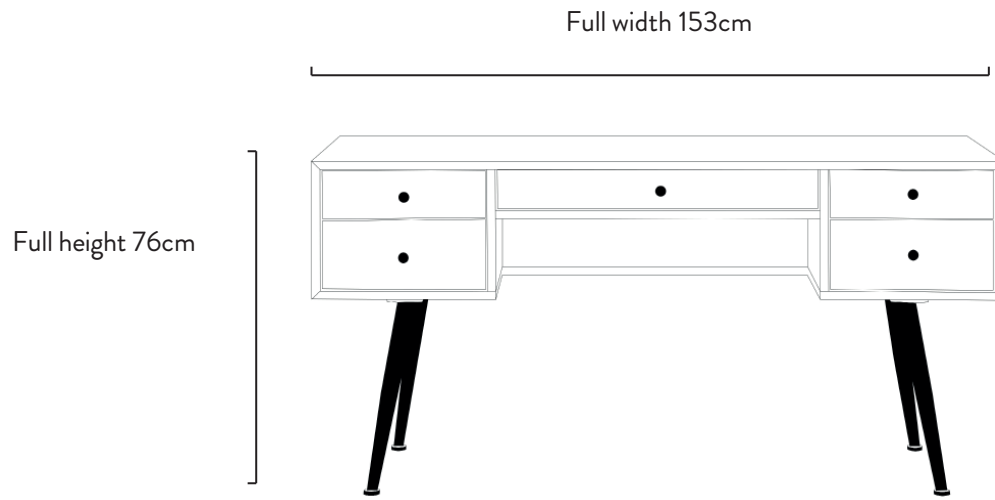

Full depth 61cm

